



# T3

## WALK-BEHIND FLOOR SCRUBBER

- Just-scrubbed floors are immediately clean, dry and safe for traffic with ec-H2O™ and FaST® technologies
- 75% lower sound level (68.5 dBA)
- Easily cleanable, sanitary Hygenic® solution and recovery tanks

Lease a Tennant T3 from \$55 or T3 ecH20 from \$59 per week + GST

For more information contact PowerVac on 08 9242 4751



Link to PowerVac  
website and video



A HIGH-PERFORMANCE SCRUBBER TO  
MATCH YOUR HIGHER STANDARDS WITH  
ec-H2O™ OR FaST® TECHNOLOGY



IMPROVE ENVIRONMENTAL HEALTH IN YOUR FACILITY

Exclusive Hygenic® tanks allow for easy access and sanitization, reducing mold, bacteria and other contaminants that can grow in enclosed tanks.

QUIETLY CLEAN IN NOISE-SENSITIVE ENVIRONMENTS

At only 68.5 decibels, the T3 is 75% quieter than leading competitive models – comparable to normal conversation levels.

DON'T LEAVE BEHIND CLEANING SOLUTION

Even around 180-degree turns, the T3's equal-pressure, parabolic squeegee recovers all cleaning solution from the floor.

ENGINEERED FOR SAFETY

Minimize the risk of slip-and-fall injuries with clean, dry, and safe floors by scrubbing with ec-H2O™ and FaST® technologies.

Reduce operator fatigue and increase productivity. Ergonomic design makes cleaning with the T3 more comfortable.

Increase scrubbing effectiveness and quality. Clear sight lines and simple controls mean operators can focus solely on their cleaning environment.

INSIDE THE  
**T3**

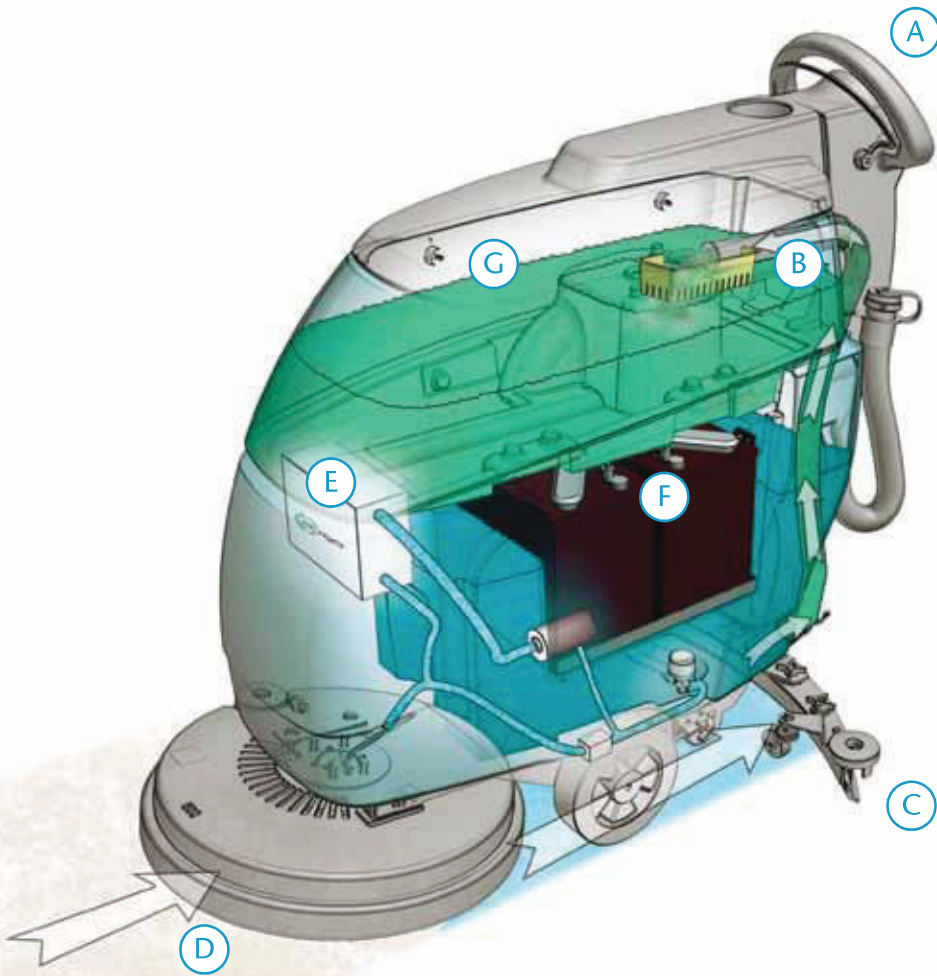

**EXCLUSIVE TECHNOLOGIES**

(optional cleaning innovations)

All technologies increase scrub time up to three times using a single tank of water.



ec-H2O™ technology electrically converts water into an innovative cleaning solution that cleans effectively, saves money, improves safety, and reduces environmental impact compared to daily cleaning floor chemicals and methods.



FaST® Foam Scrubbing Technology uses up to 70% less water and 90% less chemicals to improve floor traction as certified by NFSI, helping reduce the risk of slip and fall accidents.

- A** Easily train new operators to use the simple, intuitive controls.
- B** Solution and recovery tanks easily cleanable. Exclusive Hygenic® tanks are fully accessible for sanitization.
- C** Quickly remove and replace brushes and squeegees. Plus, with the “no hassle” squeegee system, there are no tools for maintenance, and the blade is factory set at the optimum recovery angle.
- D** Eliminate the need for follow-up passes and non-productive mop-ups. A fully self-adjusting splash skirt captures 100% of scrub deck overspray.

- E** Scrub longer on a single tank with Green Seal certified FaST® Foam Scrubbing Technology or ec-H2O™ technology.
- F** Save time and storage space with the onboard charger.
- G** Eliminate operator contact with wastewater and prevent clogged hoses/drains with the convenient debris tray.



## ENVIRONMENTAL STEWARDSHIP



**ec-H2O™ and FaST® technologies are NFSI (National Floor Safety Institute) Certified.** NFSI certified products must pass a 2-phase wet slip resistance process and have been shown to reduce the potential for slip-and-fall accidents.



**ec-H2O and FaST technologies are registered by NSF International.** NSF International is an independent, not-for-profit organization that ensures formulation and labels on these products meet appropriate food safety regulations.



**ec-H2O and FaST technologies may contribute to LEED or LEED-EBOM (Existing Building: Operations & Maintenance) points,** provided other appropriate criteria are met. For more information on obtaining LEED points, please contact your sales rep or refer to the USGBC website at: [www.usgbc.org](http://www.usgbc.org).



**FaST is a Green Seal (GS-37) Certified Detergent.** Green Seal evaluates and certifies cleaning products based on criteria such as the toxicity of the product, skin and eye irritation, skin sensitization, combustibility, toxicity to aquatic life, and packaging.



Conserve Resources



Reduce Detergents



Increase Safety



Improve Air Quality



Reduce Noise

## T3 WALK-BEHIND FLOOR SCRUBBER

### SCRUBBING SYSTEM

	17 IN PAD ASSIST	20 IN PAD ASSIST (20 IN W/DRIVE)
Cleaning path	17 in / 430 mm	20 in / 510 mm
Productivity (per hour)		
Theoretical Max	20,230 ft <sup>2</sup> / 1,900 m <sup>2</sup>	23,800 ft <sup>2</sup> / 2,200 m <sup>2</sup>
Estimated Coverage* Conventional	8,440 ft <sup>2</sup> / 780 m <sup>2</sup>	10,125 ft <sup>2</sup> / 940 m <sup>2</sup> (13,500 ft <sup>2</sup> / 1,255 m <sup>2</sup> )
ec-H2O / FaST	11,250 ft <sup>2</sup> / 1,050 m <sup>2</sup>	13,500 ft <sup>2</sup> / 1,260 m <sup>2</sup> (15,300 ft <sup>2</sup> / 1,420 m <sup>2</sup> )

### BRUSH DRIVE SYSTEM

Brush motor horsepower	1.0 hp
Brush RPM	230 rpm
Brush/pad pressure	50 lbs / 23 kg & 90 lbs / 41 kg

### SOLUTION DELIVERY SYSTEM

Solution tank description	Full access & cleanable
Solution capacity	10.5 gal / 40 L

### RECOVERY SYSTEM

Recovery tank description	Full access & cleanable
Recovery tank capacity (include demisting chamber)	15 gal / 57 L
Vacuum motor	0.5 hp – two stage
Vac motor CFM	65 cfm / 1.84 cmm
Vac motor sealed waterlift	40 in / 1,020 mm

### BATTERY SYSTEM

System voltage	24 volt
Battery amp hour rating	105 AH @ 20 hr
Battery run time (continuous cleaning rating)	2.5 hours
	130 AH @ 20 hr (155 AH @ 20 hr) 2.5 hours (3 hours)

### MACHINE SPECIFICATIONS

Product length	48 in / 1,220 mm	50.25 in / 1,280 mm
Product width (with squeegee)		30 in / 760 mm
Product height		43 in / 1,090 mm
Product weight (with batteries)	319 lbs / 145 kg	343 lbs / 156 kg 391 lbs / 177 kg
Power consumption amps	27 amp nominal	29 amp nominal (30 amp nominal)
Sound level (operator's ear)		68.5 dBA

### WARRANTY

See your local representative for warranty information

\* Estimated coverage rates use the practical speed and empty/fill time standards from the 2004 ISSA Cleaning Times handbook.

\*\* Run times are based on continuous scrubbing run times.

\*\*\* Sound levels per ISO 11201 as recommended by the American Association of Cleaning Equipment manufacturers & OSHA.

Full local parts and service from PowerVac

For an onsite demonstration contact PowerVac now on 08 9242 4751



**PowerVac**  
CLEANING EQUIPMENT & SERVICE  
[www.powervac.com.au](http://www.powervac.com.au)

PO Box 1031, Osborne Park DC, Western Australia, 6916  
Cnr Hutton & Howe St, Osborne Park, Western Australia 6017

P ++61 8 9242 4751

E [info@powervac.com.au](mailto:info@powervac.com.au)

F ++61 8 9242 4752

ABN 51 009 277 356